



# Carlinas tables

Cheekily calling to Carlo Mollino's greater influence on Oscar Tusquets, these tables were named Carlinas. Their clear surface exposes the now-visual supporting structures. Like Mollino's nature-informed pieces, the Carlinas boast punctuating twisting stretchers that hold the smoked glass tabletop.









MATERIALS AND FINISHES

Biomorphic wood triangulates on the side table and stabilises larger tables with a diagonal crossbar. The stabilising structure twists like entwined fingers, and legs come out of the table like bent knees.

COLORS



Ash stained black

Carlina Dining

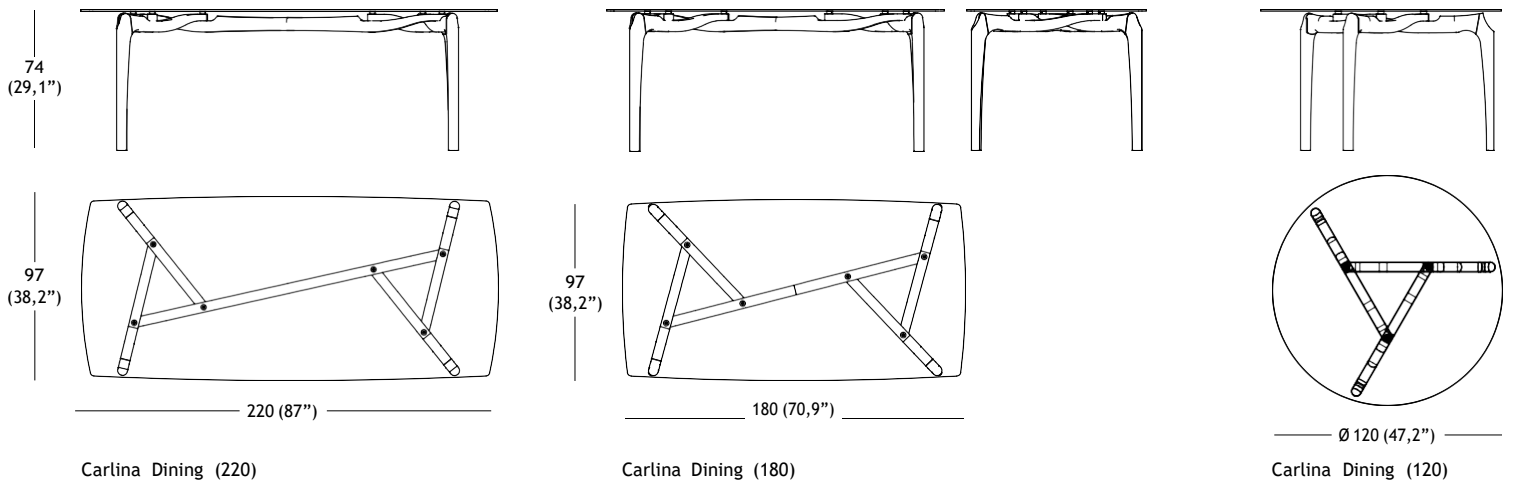

Carlina Low

